

## Wide Input CC/CV 3A Buck Converter

### General Description

AT2003Z is a wide input voltage, high efficiency step-down DC/DC converter that operates in either CV (Constant Output Voltage) mode or CC (Constant Output Current) mode. AT2003Z provides up to 3A output current at 120kHz switching frequency, and the CC level can be adjusted by changing external sensing resistor.

The AT2003Z provides full protection functions, thermal shutdown is to prevent over temperature operating from damage; cycle by cycle current limit is against over current operating of the switch; and over voltage protection (OVP) that can avoid high Vout voltage to damage circuit and capacitor.

The device is available in PSOP8-8L package and require very few external devices for operation.

### Features

- Wide Input Voltage with 9V ~ 40V Operation
- Up to 3A Output Current
- Fixed Frequency 120 kHz with Easy EMI Control
- Constant voltage and constant voltage control
- Precision Feedback Voltage 1.2V+1%
- Precision CC Limit with +5% Accuracy
- Integrated 140mohm High Side NMOS
- Internal MOS 4.5A Current Peak Protected in Cycle by Cycle Current Limit
- PSOP8-8 Package

### Applications

- Car Charger/Adaptor
- General-Purposed DC/DC Converters with Constant Current Limit
- Rechargeable Portable Devices

### Pin Configuration

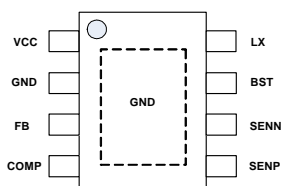

### Ordering and Marking Information

Order Number	Package	Top Marking
AT2003ZSP8	PSOP-8L	AT2003Z

Note: Aplustek products are compatible with the current IPC/JEDEC J-STD-020 requirement. They are halogen-free, RoHS compliant and 100% matte tin (Sn) plating that are suitable for use in SnPb or Pb-free soldering processes.

## Typical Application Circuit

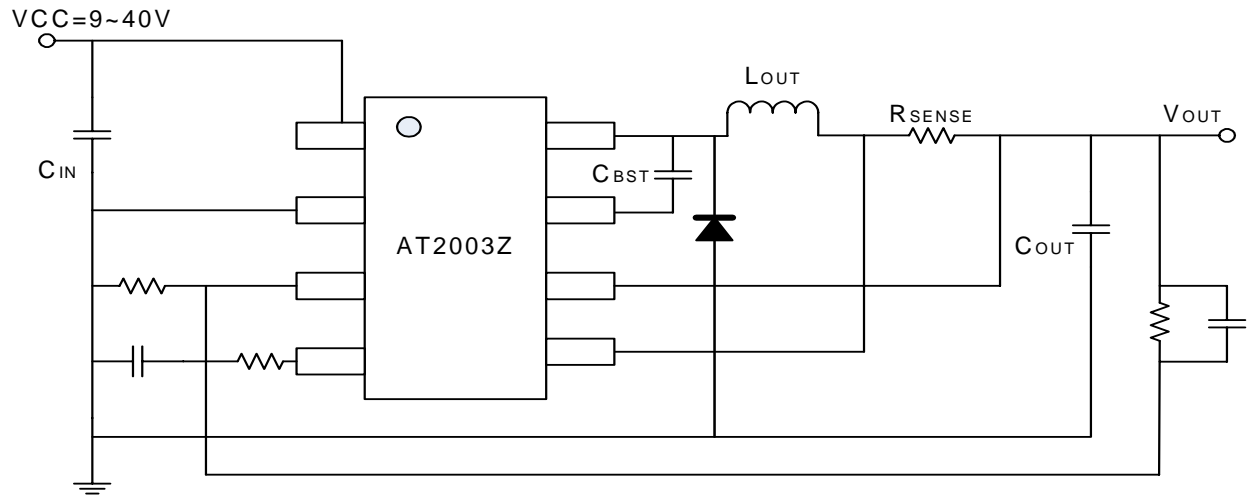

## Function Blocks

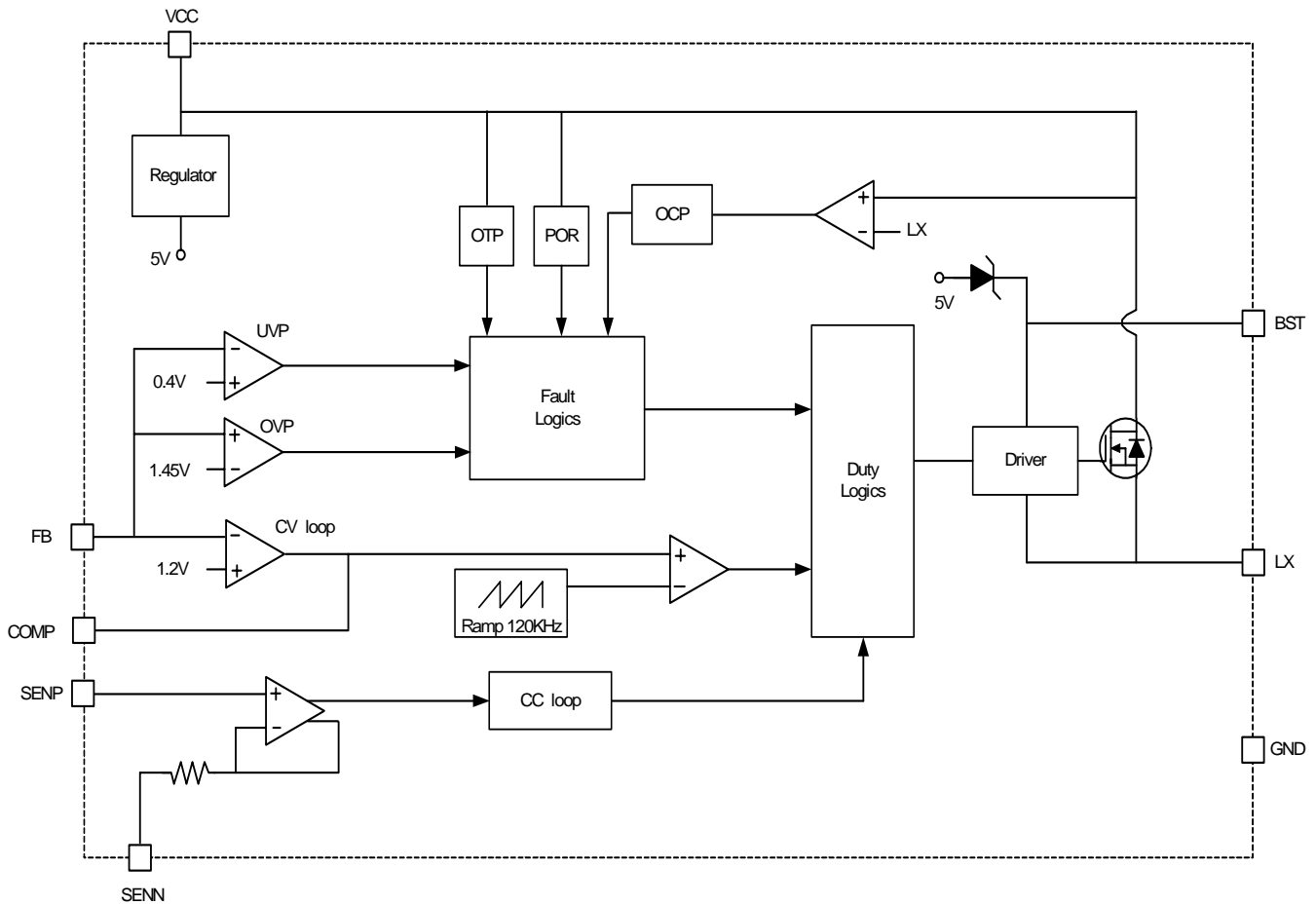

## Function Pin Description

No.	Pin Name	Pin Function
1	VCC	<b>Power Supply Input.</b> Bypass this pin with a 0.1uF ceramic capacitor to GND, placed as close to the IC as possible.
2	GND	<b>Ground.</b>
3	FB	<b>Feedback Input.</b> The voltage at this pin is regulated to 1.2V. Connect to resistor divider between output and GND to set the output voltage.
4	COMP	<b>Error Amplifier output Pin.</b> The pin is used to compensate the converter.
5	SENP	<b>Current sense positive input pin.</b>
6	SENN	<b>Current sense negative input pin.</b>
7	BST	<b>Bootstrap Bias Pin.</b> It provides power to the internal high-side MOSFET gate driver. Connect a 0.1uF capacitor from BST to LX pin.
8	LX	Power Switching Output to external Inductor.



### Absolute Maximum Ratings

(Note1)

Supply Input Voltage, $V_{CC}$	-----	-0.3V to +44V
BST to LX	-----	- 0.3V to +7V
LX to GND DC	-----	-0.3V to +44V
FB,COMP to GND DC	-----	-0.3V to +7V
Storage Temperature Range	-----	-65°C to +150°C
Junction Temperature	-----	-40°C to +150°C
Lead Temperature Range(Soldering 10sec)	-----	260°C
ESD Rating (Note2)		
HBM(Human Body Mode)	-----	2KV
MM(Mechine Mode)	-----	200V

### Thermal Characteristics

Package Thermal Resistance (Note3)

PSOP-8L $\theta_{JA}$	-----	50°C/W
PSOP-8L $\theta_{JC}$	-----	5°C/W
Power Dissipation, PD @ TA = 25°C		
PSOP-8L	-----	2.0W

### Electrical Characteristics

(  $V_{CC} = 12V, T_A = +25°C$  unless otherwise specified.)

Parameter	Symbol	Test Conditions	Min	Typ	Max	Units
<b>Supply Input Section</b>						
VCC operation range	$V_{CC,R}$		9	--	40	V
VCC UVLO threshold	$V_{CC,R}$	VCC Rising	--	8.2	--	V
	$V_{CC,F}$	VCC Falling	--	6.3	--	V
VCC operation current	$I_{CC}$	VCC=9V to 40V, COMP short to FB	--	1	1.5	mA
<b>Oscillation Section</b>						
PWM Frequency	$F_{SW}$		--	120	--	kHz
			-15%	--	+15	%
Max Duty	$D_{MAX}$		--	90	--	%
<b>PWM loop Section</b>						
Feedback reference voltage	$V_{REF}$		--	1.2	--	V
Feedback reference accuracy			-1%	--	+1%	%
COMP source current		FB<1.2V	--	85	--	uA
COMP sink current		FB>1.2V	--	85	--	uA
COMP High voltae		FB<1.2V	--	4.3	--	V
COMP Low voltae		FB>1.2V	--	0.8	--	V
<b>Fault protection Section</b>						
FB under voltage level	$V_{UVP}$		--	0.4	--	V
FB over voltage level	$V_{OVP}$		--	1.45	--	V
FB short Impedance level	$V_{SHORT}$		--	0.2	--	V
Over Tempperature level	$T_{OTP}$		--	150	--	°C
	$T_{HYS}$		--	40	--	°C



Parameter	Symbol	Test Conditions	Min	Typ	Max	Units
<b>Fault protection Section</b>						
CC Control accuracy			-5	--	+5	%
Internal Soft Start time	$T_{SS}$		--	4.5	--	mS
Fault recycle waiting time	$T_{recycle}$		--	0.5	--	S
<b>High side MOS Section</b>						
High side MOS ON resistance	$R_{DSON}$		--	0.14	--	ohm
High Side MOS peak current Limit			--	4.5	--	A

**Note 1.** Exceeding these limits may impair the life of the device. Exposure to absolute maximum rating conditions for long periods may affect device reliability.

**Note 2.**  $\theta_{JA}$  is measured with the component mounted on a high effective thermal conductivity test board in free air. The exposed pad of the package is soldered directly on the PCB.

## Typical Operation Characteristics

$V_{FB}$  vs. VCC

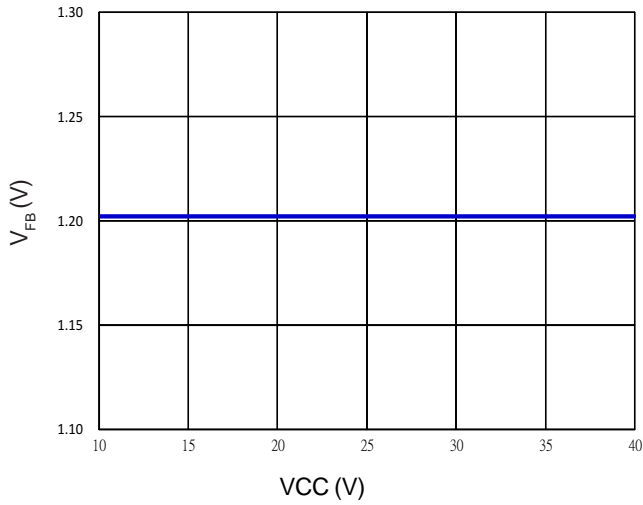

Frequency vs. VCC

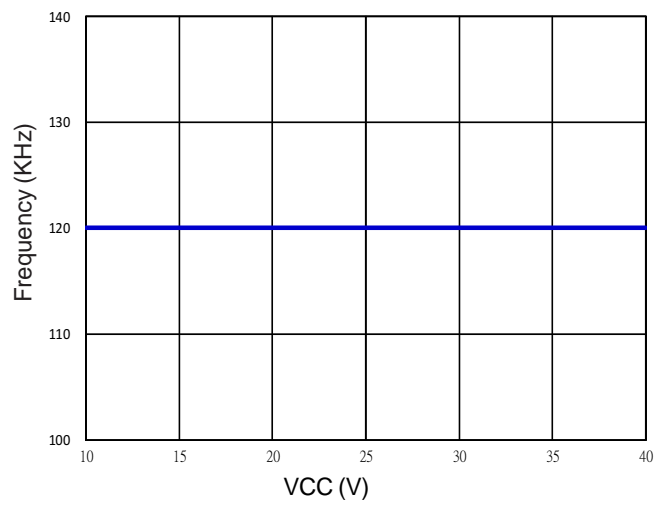

Power On from VCC

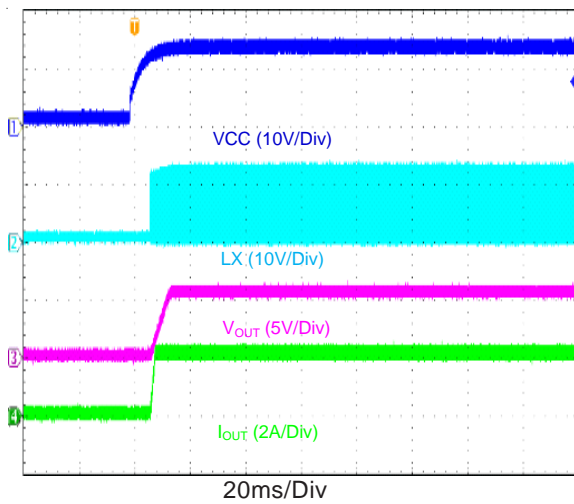

Power Off from VCC

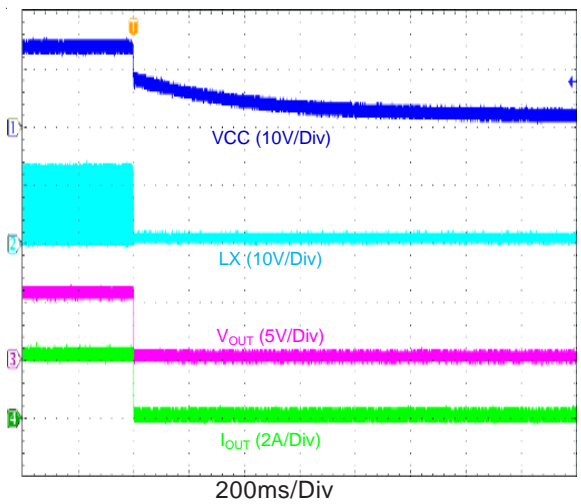

Short Circuit Enter

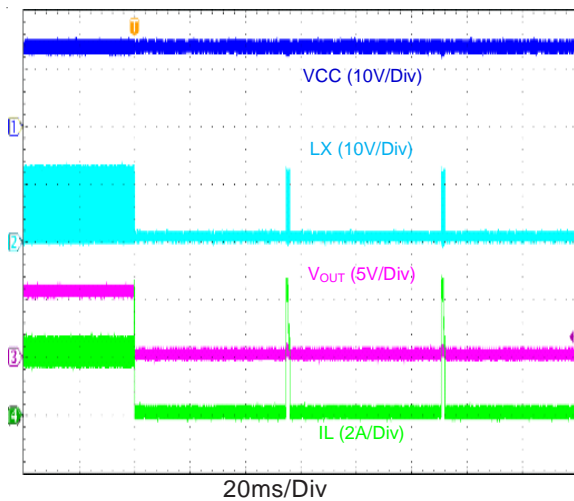

Short Circuit Recovery

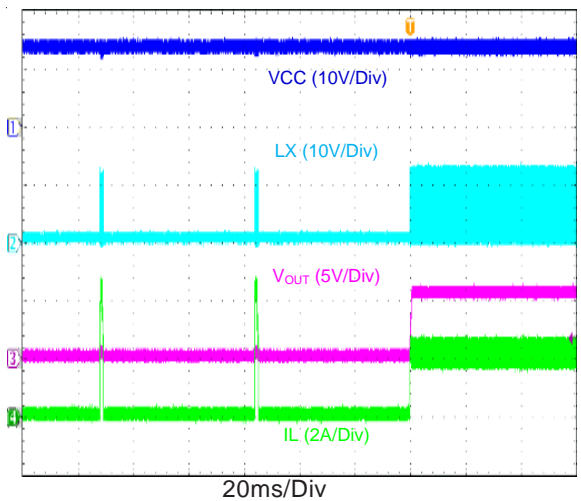

## Package Information

### PSOP-8L

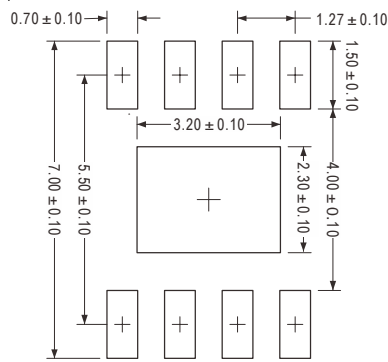

Recommended Solder Pad Layout

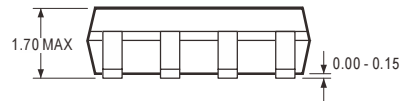
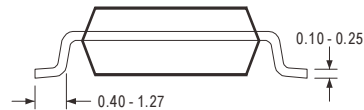
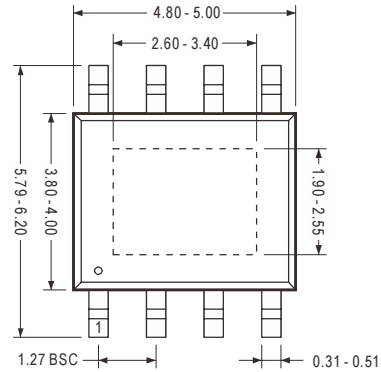

### Note

#### 1. Package Outline Unit Description:

BSC: Basic. Represents theoretical exact dimension .

MAX: Maximum dimension specified.

MIN: Minimum dimension specified.

REF: Represents dimension for reference use only. The value is not the device specification.

TYP: Represents as a typical value. The value is not the device specification.

#### 2. All linear dimensions are in Millimeters.